

## Company Information



### Location:

ERGOSEAL

346 Commerce Dr. · Carol Stream, IL 60188

### Contact:

John Hilaris

{630} 462-9600 tel · {630} 462-3600 fax

### ERGOSEAL

...is dedicated to producing the highest quality Mechanical Seals for Industrial, Marine and Aircraft applications.

#### Support Services:

- Application engineering
- Functional analysis, related reports and recommendations for application improvements
- Seal repair and replacement services
- Ergoseal will maintain agreed upon inventories of special products when unpredictable emergency requirements frequently occur.
- Many more...

**John A. Hilaris,**  
*President and CEO*



# TYPE

thirty

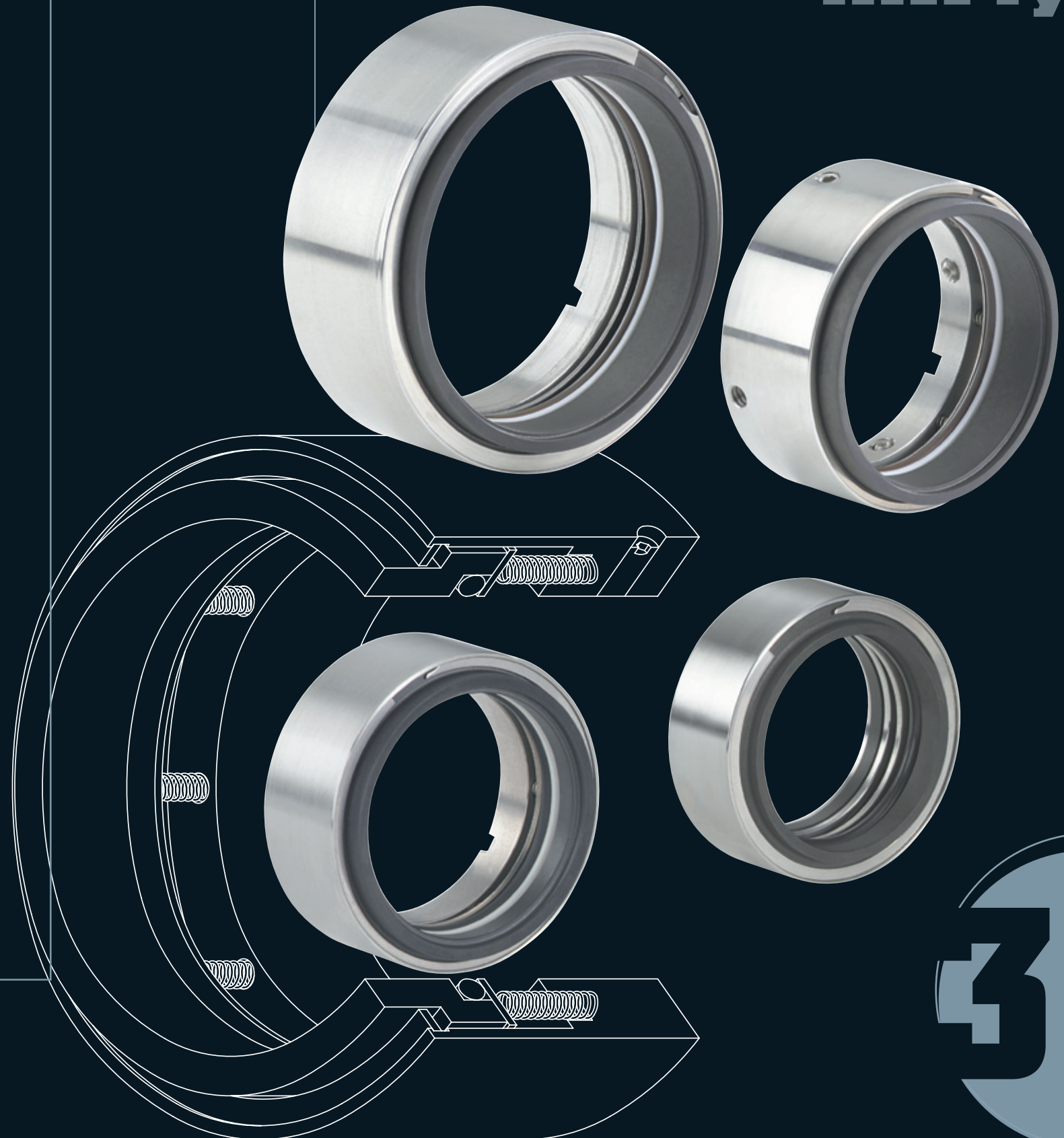

# specs

# type 30's

## type 30

### Description:

This seal is mounted on the shaft, it has a low radial cross section making it ideal when cavity dimensions are limited. For even shallower cavity dimensions, specify with a "T" suffix. Can be driven with set screws or a pin.

### Typical Applications:

Petrochemical pumps,  
Mixers, Agitators

### Performance Parameters:

Pressure:  
350 psi O.D.  
25 psi I.D.

### Temperature:

Up to 750 °F

### Speed:

4,500 sfpm

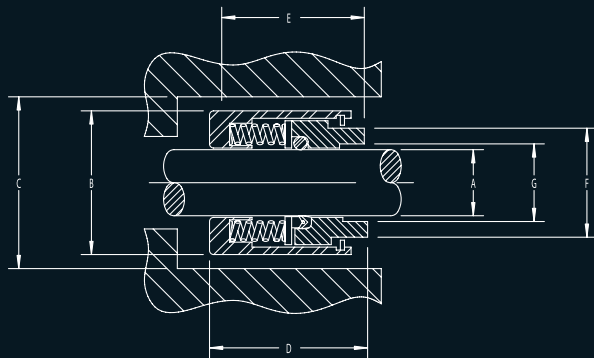
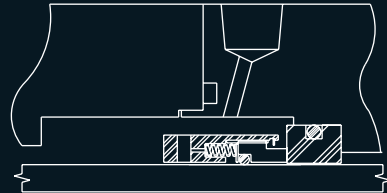

## type 39

### Description:

This seal is similar to a Type 30 seal, but it utilizes a PTFE wedge instead of an o-ring. It has a low radial cross section. For even shallower cavity dimensions, specify with a "T" suffix.

### Typical Applications:

Chemical, Refinery, and Petrochemical  
Pumps, and Mixers, especially when  
handling hydrochloric, hydrofluoric,  
nitric, phosphoric, or sulfuric acids.

### Performance Parameters:

Pressure:  
350 psi O.D.  
25 psi I.D.

### Temperature:

Up to 750 °F

### Speed:

4,500 sfpm

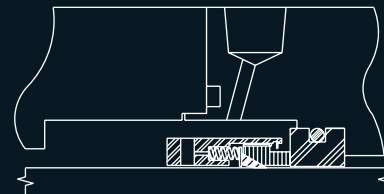

Dash	A Shaft	B Seal O.D.	C Bore (min)	D Op.Length <small>+0.050 -0.020</small>	E Set Screw	F Face O.D. (max)	G Face I.D. (min)
-8	0.500	0.938	1.063	0.813	0.647	0.802	0.620
-10	0.625	1.063	1.188	0.750	0.585	0.927	0.745
-16	1.000	1.438	1.563	1.000	0.815	1.303	1.119
-18	1.125	1.563	1.688	1.000	0.815	1.430	1.242
-20	1.250	1.688	1.813	1.000	0.815	1.552	1.370
-22	1.375	1.938	2.063	1.125	0.915	1.715	1.495
-24	1.500	1.938	2.063	1.125	0.940	1.802	1.620
-26	1.625	2.188	2.375	1.156	0.946	1.953	1.745
-28	1.750	2.313	2.438	1.375	1.173	2.078	1.870
-30	1.875	2.500	2.625	1.375	1.165	2.215	1.995
-32	2.000	2.625	2.750	1.375	1.165	2.340	2.120
-34	2.125	2.750	2.938	1.688	1.477	2.465	2.245
-36	2.250	2.844	2.969	1.375	1.165	2.576	2.370
-38	2.375	3.000	3.125	1.688	1.477	2.715	2.495
-40	2.500	3.125	3.250	1.375	1.165	2.840	2.620
-42	2.625	3.250	3.375	1.688	1.477	2.965	2.745
-44	2.750	3.375	3.500	1.688	1.477	3.090	2.870
-46	2.875	3.500	3.625	1.688	1.477	3.215	2.995
-48	3.000	3.625	3.750	1.688	1.477	3.340	3.120
-50	3.125	3.750	3.875	1.688	1.477	3.465	3.245
-52	3.250	3.875	4.000	1.688	1.477	3.590	3.370
-54	3.375	4.000	4.125	1.688	1.477	3.715	3.495
-56	3.500	4.125	4.250	1.688	1.477	3.840	3.620
-60	3.750	4.375	4.500	1.688	1.477	4.090	3.870

## type 30B

### Description:

This seal is similar to the Type 30 seal, but it is balanced of O.D. pressure.

### Typical Applications:

Petrochemical pumps,  
Mixers, Agitators

### Performance Parameters:

Pressure:  
2000 psi O.D.  
750 psi I.D.

### Temperature:

Up to 750 °F

### Speed:

4,500 sfpm

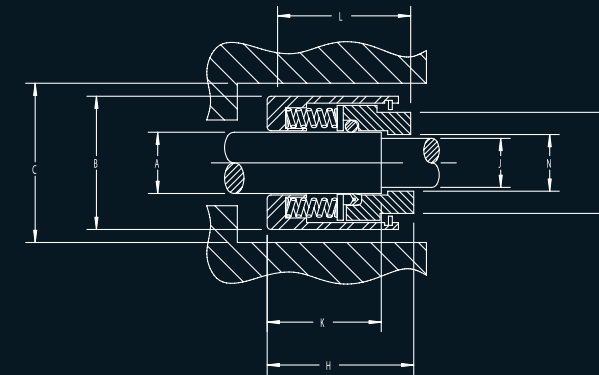
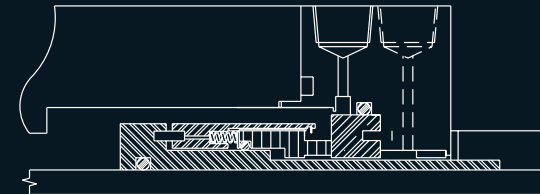

## type 39B

### Description:

This seal is similar to the Type 39 seal, but it is balanced for O.D. pressure.

### Typical Applications:

Similar to Type 39

### Performance Parameters:

Pressure:  
750 psi O.D.  
25 psi I.D.

### Temperature:

Up to 750 °F

### Speed:

4,500 sfpm

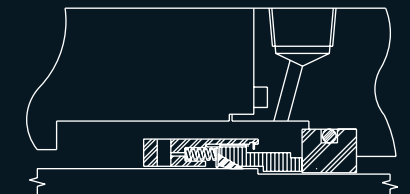

Dash	A Shaft	H Op.Length <small>+0.050 -0.020</small>	J Shaft <small>+0.001 -0.001</small>	K Length <small>+0.050 -0.020</small>	L	M Face O.D. (max)	N Face I.D. (min)
-8	0.500	-	-	-	-	-	-
-10	0.625	-	-	-	-	-	-
-16	1.000	1.313	0.875	0.969	1.127	1.201	0.931
-18	1.125	1.375	1.000	1.031	1.190	1.326	1.056
-20	1.250	1.375	1.125	1.031	1.190	1.451	1.181
-22	1.375	1.688	1.125	1.344	1.477	1.562	1.292
-24	1.500	1.438	1.250	1.094	1.252	1.715	1.405
-26	1.625	1.594	1.375	1.156	1.383	1.840	1.530
-28	1.750	1.750	1.500	1.156	1.548	1.975	1.665
-30	1.875	1.750	1.625	1.156	1.540	2.100	1.790
-32	2.000	1.750	1.750	1.156	1.540	2.227	1.917
-34	2.125	2.062	1.875	1.563	1.852	2.352	2.042
-36	2.250	1.750	2.000	1.250	1.540	2.507	2.137
-38	2.375	2.062	2.125	1.563	1.852	2.644	2.274
-40	2.500	2.062	2.250	1.250	1.540	2.769	2.399
-42	2.625	2.062	2.375	1.563	1.852	2.894	2.524
-44	2.750	2.062	2.500	1.563	1.852	3.019	2.649
-46	2.875	2.062	2.625	1.563	1.852	3.144	2.774
-48	3.000	2.062	2.750	1.563	1.852	3.269	2.899
-50	3.125	2.062	2.875	1.500	1.852	3.396	3.026
-52	3.250	2.062	3.000	1.500	1.852	3.521	3.151
-54	3.375	2.062	3.125	1.500	1.852	3.686	3.240
-56	3.500	2.062	3.250	1.500	1.852	3.811	3.365
-60	3.750	2.062	3.500	1.500	1.852	4.061	3.615

