



346 Commerce Dr., Carol Stream, IL 60188
 Phone:(630) 462-9600 • Fax:(630) 462-3600
 seals@ergoseal.com
 An ISO 9001:2008 Certified Company

SEAL DESIGN DATA SHEET

COMPANY		
ADDRESS		PHONE
CITY	STATE	ZIP
ATTENTION OF		TITLE
OPERATIONAL DATA		
EQUIPMENT MAKE, TYPE, and/or SIZE		
METAL PARTS MADE OF		
PRESSURE RANGE AT SEAL FROM		TO
DIRECTION OF PRESSURE		
TEMPERATURE RANGE		FROM TO
SHAFT DIAMETER		
SHAFT RPM		SPEED (F.P.M.) AT O.D. OF SEAL FACE
FLUID BEING SEALED		
DOES FLUID CRYSTALLIZE?		IS FLUID DANGEROUS OR TOXIC?
DOES FLUID HARDEN?		IS FLUID CORROSIVE?
PH VALUE	SPECIFIC GRAVITY	VISCOSITY
SOLIDS PRESENT?(IF SO, WHAT KIND)		
IS CLEAN LIQUID FLUSH AVAILABLE?		
PERMISSIBLE LEAKAGE (cc/hr.)		SEAL LIFE REQUIRED
TYPICAL RUNNING CYCLE (TIME ON/OFF)		
SHAFT END PLAY		SHAFT RUN OUT T.T.R.

NEW APPRECIATION	YES()NO()
CONVERSION	YES()NO()
IF CONVERSION, PLEASE GIVE DETAILS OF PRESENT SEAT	
IF NEW, WHEN WILL PRODUCTION BEGIN?	

DESIGN DRAWING

SPECIFY DIMENSIONS IN SPACES BELOW OR ATTACH DRAWING

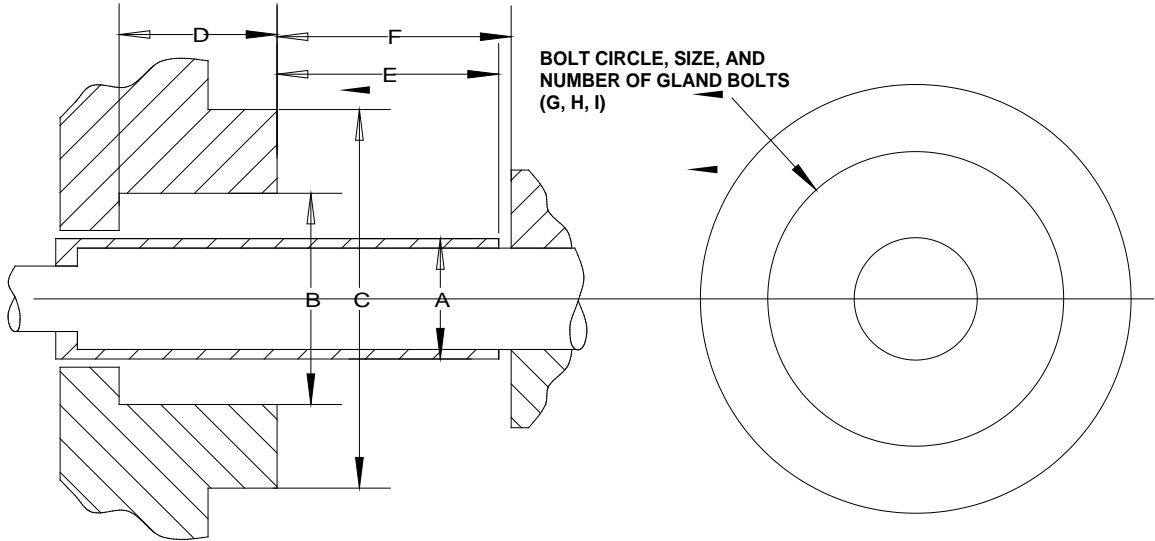

A) SHAFT OR SLEEVE OD

B) STUFFING BOX BORE

C) REGISTER

D) STUFFING BOX DEPTH

E) REGISTER TO END OF SLEEVE OR SHAFT

F) DISTANCE TO FIRST OBSTRUCTION

G) GLAND BOLT CIRCLE

H) SIZE OF BOLT HOLES

I) NUMBER OF BOLTS

PRODUCTION REQUIREMENTS

THIS DATA WILL AFFECT DESIGN AND PRODUCT ECONOMIES

QUANTITIES EACH ORDER

TOTAL QUANTITIES

YEARLY QUANTITIES

MONTHLY QUANTITIES